

Standard Installation

Fire Damper Models: 319, 319(SS), D39

APPLICATION

This fire damper is intended to restrict the passage of flame. The standard installation requires that the damper is positioned so that the closed plane of the blades is within the fire rated masonry/concrete or metal or wood framed gypsum wallboard barrier.

This damper may be mounted in the vertical or horizontal position with the damper blades running horizontally. Airflow can be from either direction. When mounted in the vertical position, the damper can be mounted in a fire barrier constructed of masonry/concrete or metal or wood framed gypsum wallboard materials. When mounted in the horizontal positions, the damper can only be mounted in a fire barrier constructed of masonry/concrete materials.

MULTIPLE PANEL SIZE LIMITATIONS

Orientation	Horizontal			Vertical		
	Max Panel	Max Assy 165°	Max Assy 212°	Max Panel	Max Assy 165°	Max Assy 212°
319A	48"Wx48"H	72"Wx36"H	72"Wx36"H	36"Wx36"H	72"Wx72"H	72"Wx72"H
319B	48"Wx43"H duct (48"Wx48"H frame)	72"Wx32"H duct (72"Wx36"H frame)	72"Wx32"H duct (72"Wx36"H frame)	36"Wx32"H duct (36"Wx36"H frame)	72"Wx68"H duct (72"Wx72"H frame)	72"Wx68"H duct (72"Wx72"H frame)
319C	46"Wx42"H duct (48"Wx48"H frame)	70"Wx31"H duct (72"Wx36"H frame)	70"Wx31"H duct (72"Wx36"H frame)	34"Wx31"H (36"Wx36"H frame)	70"Wx67"H (72"Wx72"H frame)	70"Wx67"H (72"Wx72"H frame)
319AX	48"Wx48"H	48"Wx48"H	48"Wx48"H	36"Wx36"H	36"Wx36"H	36"Wx36"H
319BX	48"Wx43"H duct (48"Wx48"H frame)	48"Wx43"H duct (48"Wx48"H frame)	48"Wx43"H duct (48"Wx48"H frame)	36"Wx32"H duct (36"Wx36"H frame)	36"Wx32"H duct (36"Wx36"H frame)	36"Wx32"H duct (36"Wx36"H frame)
319CX	46"Wx42"H duct (48"Wx48"H frame)	46"Wx42"H duct (48"Wx48"H frame)	46"Wx42"H duct (48"Wx48"H frame)	34"Wx31"H (36"Wx36"H frame)	34"Wx31"H (36"Wx36"H frame)	34"Wx31"H (36"Wx36"H frame)
319A(SS)	not available	not available	not available	47"Wx48"H	93"Wx48"H	93"Wx48"H
319B(SS)	not available	not available	not available	47"Wx42"H duct (47"Wx48"H frame)	93"Wx42"H duct (93"Wx48"H frame)	93"Wx42"H duct (93"Wx48"H frame)
319C(SS)	not available	not available	not available	45"Wx41"H duct (47"Wx48"H frame)	91"Wx41"H duct (93"Wx48"H frame)	91"Wx41"H duct (93"Wx48"H frame)
D39A	24"Wx24"H	24"Wx24"H	not available	36"Wx36"H	72"Wx36"H	72"Wx36"H
D39B	24"Wx21"H duct (24"Wx24"H frame)	24"Wx21"H duct (24"Wx24"H frame)	not available	36"Wx32"H duct (36"Wx36"H frame)	72"Wx32"H duct (72"Wx36"H frame)	72"Wx32"H duct (72"Wx36"H frame)
D39C	22"Wx20"H duct (24"Wx24"H frame)	22"Wx20"H duct (24"Wx24"H frame)	not available	34"Wx31"H duct (36"Wx36"H frame)	70"Wx31"H duct (72"Wx36"H frame)	70"Wx31"H duct (72"Wx36"H frame)
D39AX	24"Wx24"H	24"Wx24"H	not available	36"Wx36"H	36"Wx36"H	36"Wx36"H
D39BX	24"Wx21"H duct (24"Wx24"H frame)	24"Wx21"H duct (24"Wx24"H frame)	not available	36"Wx32"H duct (36"Wx36"H frame)	36"Wx32"H duct (36"Wx36"H frame)	36"Wx32"H duct (36"Wx36"H frame)
D39CX	22"Wx20"H duct (24"Wx24"H frame)	22"Wx20"H duct (24"Wx24"H frame)	not available	34"Wx31"H duct (36"Wx36"H frame)	34"Wx31"H duct (36"Wx36"H frame)	34"Wx31"H duct (36"Wx36"H frame)

SUPPLEMENTAL INSTALLATION INSTRUCTIONS / SUBMITTAL DATA

Sleeve Extension
Integral Duct Access Door
Flanged Connections
Steel Deck
Security Bars
Transitions
Sleeves

INSTALLATION

1. **General:** The installation of the damper and all duct connections to the damper sleeve shall conform to NFPA-90A and the SMACNA Fire, Smoke and Radiation Damper Installation Guide. All duct connections shall also conform to UL555.
2. **Multiple Panel / Multiple Section Assembly:** Refer to page 5 for details.
3. **Sleeves:** Sleeves are required for the proper installation of fire rated dampers, but need not be factory mounted. Sleeves shall be the same gauge or heavier as the duct to which it is attached. Gauges shall conform to SMACNA or ASHRAE duct standards. A field supplied sleeve is attached to the damper frame with 1" long welds. Fasteners shall be staggered on each side of the damper frame on 6" maximum centers and 2-³/₄" maximum from each corner. The sleeve shall not extend more than 6" beyond the fire barrier unless the sleeve includes an access door. If the sleeve includes an access door, the sleeve may extend up to a maximum of 16" beyond the fire barrier.
4. **Expansion Clearance:** The opening in the wall for the fire rated damper shall be sized to provide expansion clearance between the sleeve and the opening. The minimum expansion clearance shall be the greater of 1/4" or 1/8" (³/₁₆" for stainless steel) per foot of overall damper/sleeve width and height. The maximum expansion clearance shall not exceed 1/8" (³/₁₆" for stainless steel) per foot of overall damper/sleeve width and height plus 2".

Example: For a galvanized damper with exact outside dimensions of 36"W x 48"H, the gap at the top plus the gap at the bottom must be between 0.5" and 2.5". The gap at the left side plus the gap at the right side must be between 0.375" and 2.375". The damper can be located anywhere in the opening and need not be centered.
5. **Damper Orientation:** Dampers mounted vertically must be installed so the blades are at the top. The damper can be positioned so that airflow is from either direction. For dampers with springs, it is best to have access to the side of the damper opposite the leading blade edge. The pull ring option can be utilized when this is not practical. Dampers mounted horizontally must be installed so that the blade lock points are facing downward. The airflow can be from either direction. It is best to have access to the side at the damper opposite the leading blade edge (top side). The pull ring option can be utilized when this is not practical.
6. **Retaining Angle Attachment:** Perimeter retaining angles shall increase in size, proportionately, so there will be a minimum of 1" overlap on the wall, including at the corners. The angles shall be flush against the barrier. The leg attached to the damper can turn away from or into the opening. The perimeter mounting angles shall be fastened on all four sides and on both faces of the damper to the sleeve only, with 1/4" diameter steel or stainless steel nuts and bolts or by tack welding with beads 1" in length. All connections shall be spaced on 6" maximum centers and 2-³/₄" maximum from each corner (a minimum of 2 fasteners are required per side). Perimeter retaining angles shall be a minimum of 1-¹/₂" x 7/8" x 16-GA steel. Corners of angles are not welded together for dampers with width or height dimensions exceeding 24". For dampers 24"W x 24"H or smaller, the corners of the perimeter mounting angles can be welded. Some local codes may not allow welded corners. Attachment of these angles must not restrict operation of the damper. Perimeter retaining angles and their mounting fasteners are not typically supplied with the damper.
7. **Caulking:** Caulk shall be one of the following: Dow Corning RTV732, Silco Sil-Bond RTV 4500, General Electric IS808, or Novagard RTV300. Caulking is allowed between the retaining angles and the damper sleeve, and between the retaining angles and the face of the floor or wall construction. Caulking is not allowed between the damper sleeve and the wall or floor inside the opening.

Breakaway flange caulking shall be Design Polymeric's DP1010 or Precision's PA2084T.



INSTALLATION (CONTINUED)

8. **Duct Connections:** All connecting ducts shall not be continuous, but shall terminate at the fire damper sleeve. Duct connections not listed as breakaways shall be considered rigid. For rigid type duct connections, the sleeve shall be a minimum of 16-GA on dampers not exceeding 36" wide or 24" high or 24" diameter and 14-GA on larger units. Maximum sleeve thickness shall not exceed 10-GA galvanized steel. Dampers supplied with thinner sleeves require a breakaway connection. The following breakaway duct-to-sleeve connections may be used: Plain "S" Slip, Double "S" Slip, Inside Slip, Hemmed "S" Slip, Standing "S" Slip, Standing "S" Slip (Bar Reinforced), Standing "S" Slip (Angle Reinforced), and Standing "S" Slip (Alternate Bar). Breakaway joints shall have no more than two No. 10 sheet metal screws on each side and on the bottom. The screws shall penetrate both sides of the slip pocket. When a breakaway joint is used along the top and bottom duct connection, a flat drive slip no longer than 20 inches is permitted on the two sides.

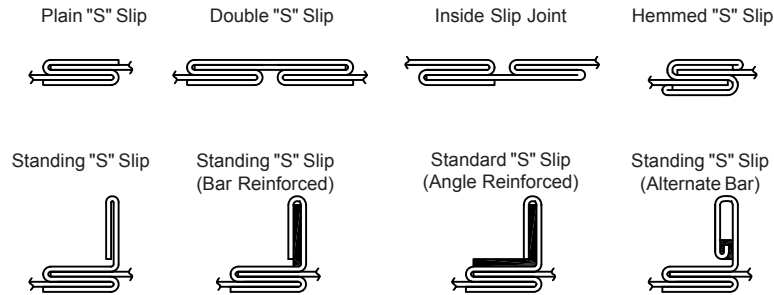

The factory supplied round/oval transition provides the breakaway connection if the following conditions are satisfied.

1. Round duct diameter is no larger than 36".
2. Oval duct size is no larger than 71"W x 30"H.
3. Duct gauges conform to the SMACNA or ASHRAE standard.
4. An oval duct or round duct less than or equal to 24" is attached to the transition collar with #8 sheet metal screws (a minimum of 4 fasteners per connection). A round duct diameter greater than 24" is attached to the transition collar with #10 sheet metal screws (a minimum of 5 fasteners per connection).

Dampers with round/oval transitions that fall outside of these restrictions must use a 4" wide drawband connection as shown in the SMACNA Fire, Smoke, and Radiation Damper Installation Guide.

9. **Maintenance:** Dampers shall be maintained at intervals as stated in NFPA 90A and 92A. Local codes or building conditions may require more frequent inspections and maintenance. A duct access door is to be located on one side of each damper for periodic inspection and maintenance.

STANDARD MOUNTING DETAILS

Type A, Vertical

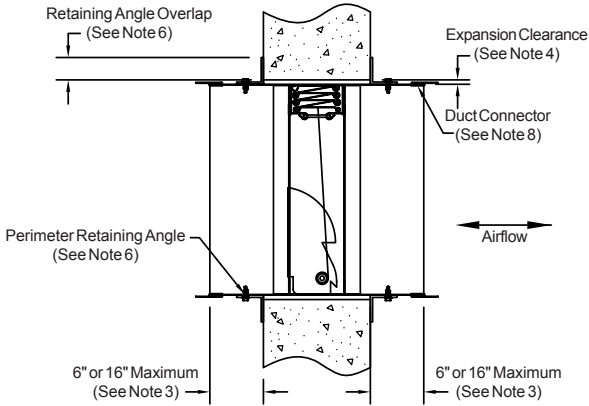

Type B, Factory Sleeve, Vertical

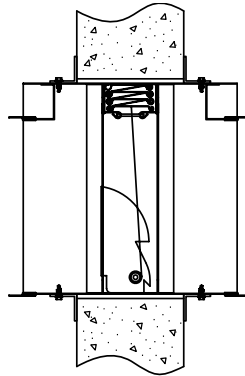

Type C, Factory Sleeve, Vertical

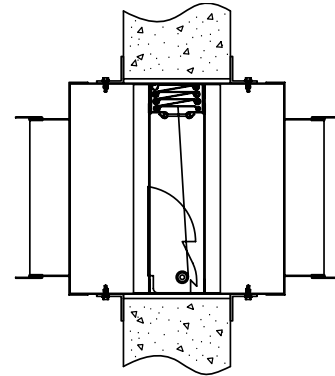

Type C, Factory Sleeve, Horizontal

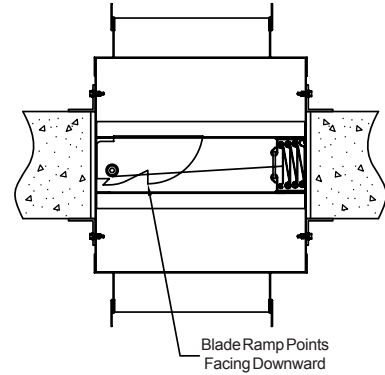

Type A, Horizontal

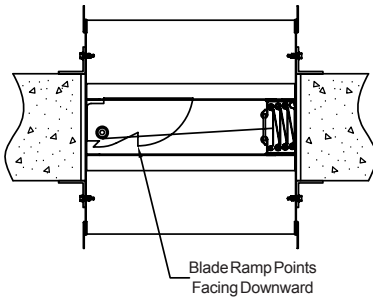

Type B, Factory Sleeve, Horizontal

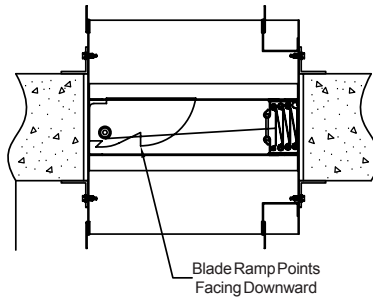

Type B, Field Sleeve, Vertical

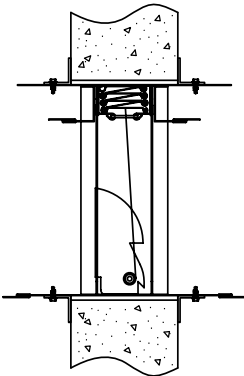

Alternative Type B, Field Sleeve, Vertical

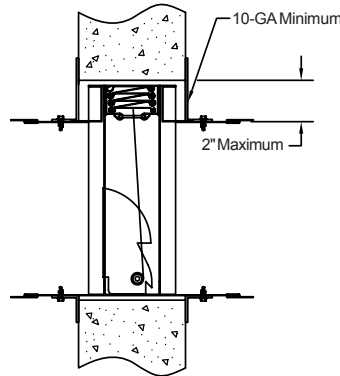

Type C, Field Sleeve, Vertical

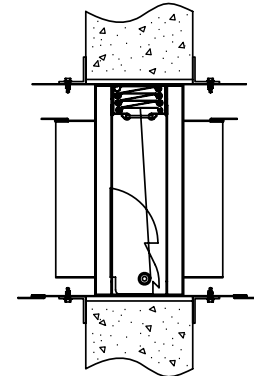

Type B, Field Sleeve, Horizontal

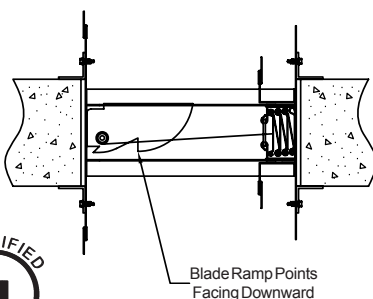

Alternative Type B, Field Sleeve, Horizontal

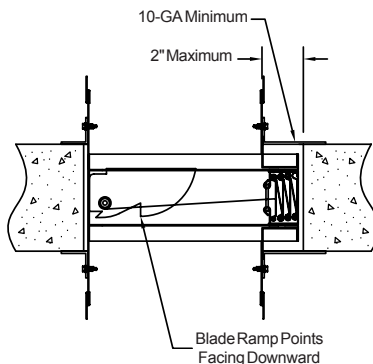

Type C, Field Sleeve, Horizontal

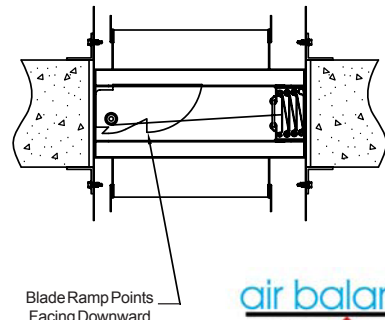

MULTIPLE PANEL / MULTIPLE SECTION INSTALLATION DETAILS

1. Damper assemblies ordered without factory mounted sleeves typically ship in individual panels to be field assembled.
2. Damper assemblies ordered with factory mounted sleeves ship assembled. Due to shipping limitations large damper assemblies may require more than one ship section. If more than one ship section is required, each ship section will be individually sleeved.
3. Mullion stiffeners are required per the illustrations below. The details shown are typical for all mullions in the same direction for that mounting orientation. For ship loose panels, mullion stiffeners are typically not provided by the factory. For single ship section sleeved dampers, mullion stiffeners will ship assembled as required. For multiple ship section sleeved dampers, the mullion stiffeners will ship assembled as required within each sleeved section. Mullion stiffeners are not required between the sleeved sections.
4. For installations where the wall/floor opening is larger than the maximum assembly size, the Local Authority Having Jurisdiction must approve a mullion to separate the large opening into smaller openings.
5. Mullion details specified are based on the fire ratings qualification tests. The user is responsible for additional structural supports of multiple section dampers when required by elevated air pressure differential in the closed position and in some cases seismic loading.

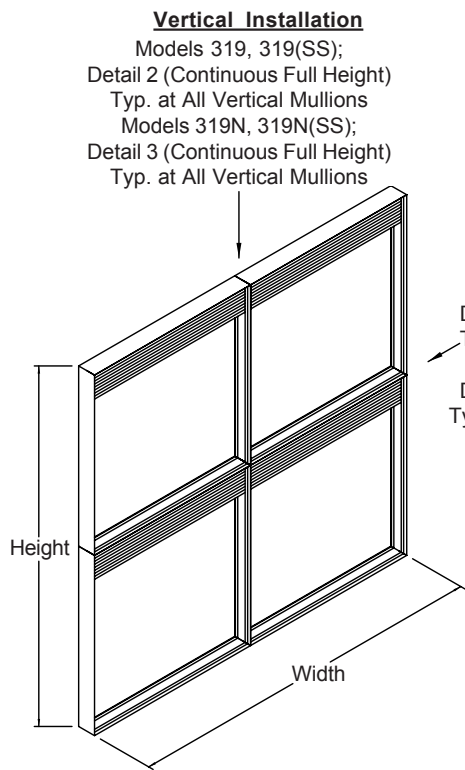

Models 319, 319(SS);
 Detail 2 (Broken Full Width)
 Typ. at All Vertical Mullions
 Models 319N, 319N(SS);
 Detail 3 (Broken Full Width)
 Typ. at All Horizontal Mullions

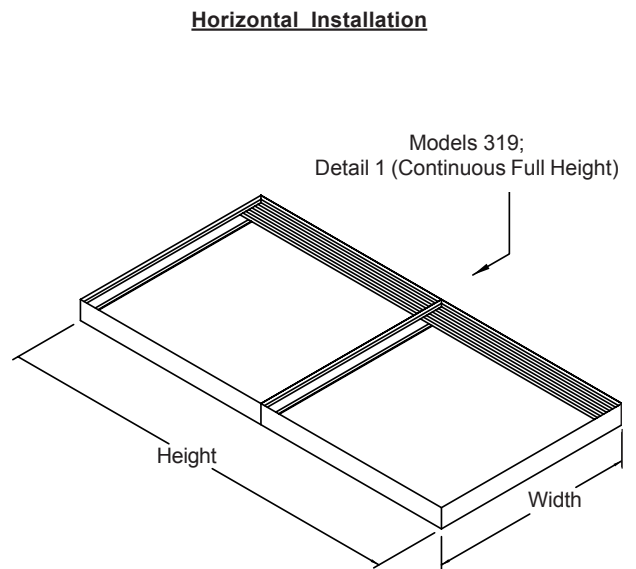

DETAIL 1

1/2" Long Beads on 8" Max. Centers on Both Faces
 OR
 1/4" Dia. Bolts and Nuts on 8" Max. Centers on Both Faces

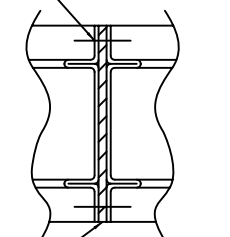

4-7/8" x 14-GA Mullion Plate
 (Same Material as Damper)

DETAIL 2

1" Long Welds, on 7" Max. Centers, 2-3/4" Max. from Ends Staggered on Both Faces.

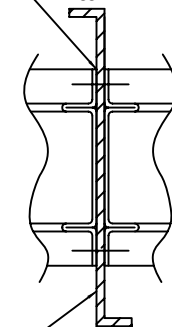

7/8" x 7 x 7/8" x 14-GA Mullion Zee
 (Same Material as Damper)

DETAIL 3

1" Long Weld, on 7" Max. Centers, 2-3/4" Max. from Ends Staggered on Both Faces and Continuously Welded to Sleeve.

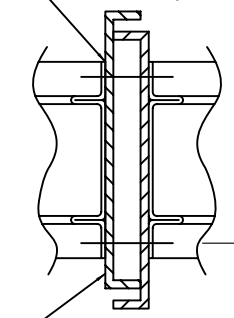

(2) 1" x 6-7/8" x 1-7/8" x 14-GA Mullion Channels Continuously Welded Together (Same Material as Damper)

This page intentionally left blank.

